

داتیسکار



شرکت تولیدی صنعتی

D A T I S K A R
INDUSTRIAL CO.

Air Washer / Air Handling Unit





شرکت تولیدی صنعتی
داتیس کار

Datis Kar Air Handling Units are designed for a variety of commercial institutional industrial and residential application such as: shopping centers, hospitals and office buildings .and are assembled and tested to meet our high quality standards.

FAN SECTIONS including all rotating assemblies ,fan wheels shafts sheaves and pulleys are balanced both statically and dynamically to assure smooth and quiet operation.

TUBES: Standards coils are designed with 5/8" copper tubes with possible alternate material selection of copper-nickel carbon steel brass and stainless of copper-nickel carbon steel brass and stainless steels to meet specific application needs. Tube diameters of 1/2", 3/4" are also available.

FILTER SECTIONS: Aluminum mesh filter, Rolomatic, HEPA, ULPA, bag activated carbon, and oil filters shall be provided as per request.

COILS: Datis kar offers chilled water, hot water, DX, steam and non-freeze steam coils in a number of configuration which cover the entire range of air conditioning and industrial applications.

COIL DIAGRAM AND CIRCUITING DEFINITION

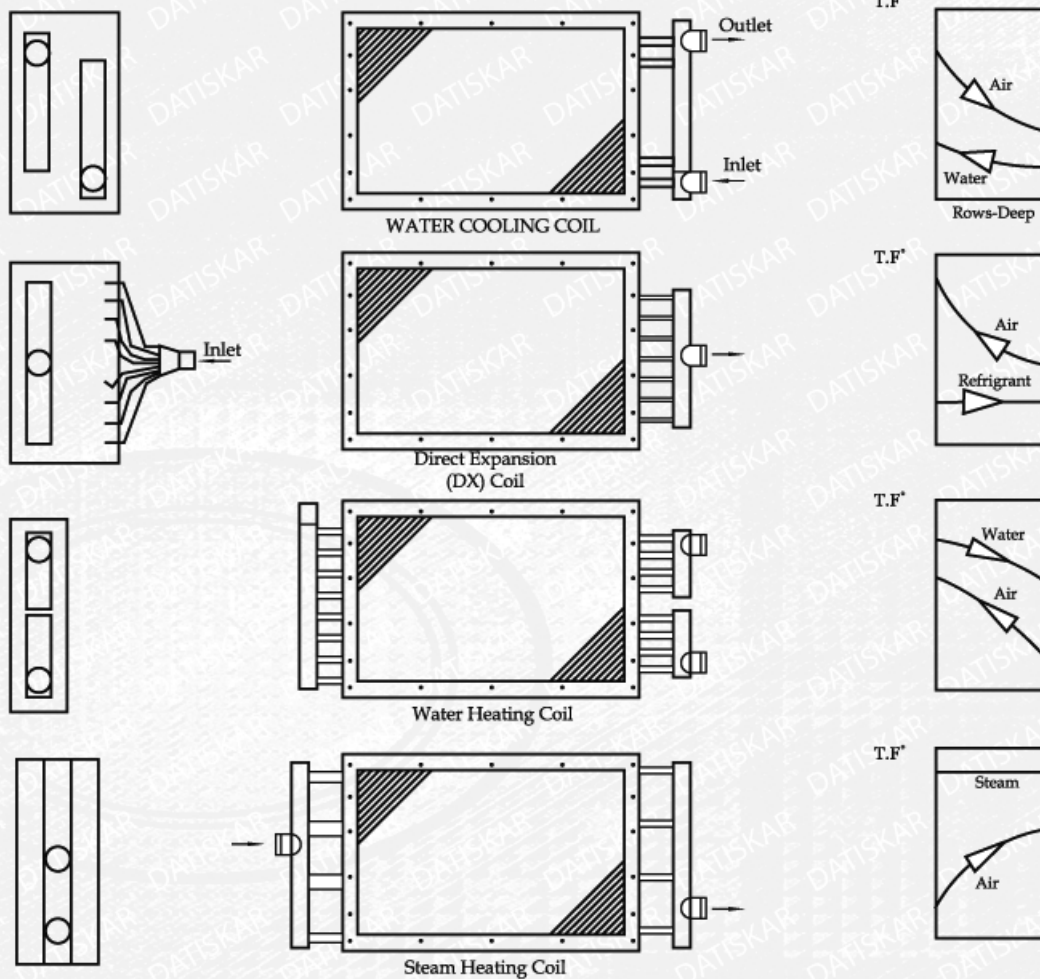

COIL TYPES & TEMPERATURE PROFILES THROUGH THE COILS

NOMINAL CAPACITY RATING

TABLE1:

MODEL	CFM	B°F	EWB° F	Cooling Capacity (k.B.H)			EDB°F	EWB° F	DX-COIL CAPACITY			
				4ROW	6ROW	8ROW			8FPI		14FPI	
									4ROW	6ROW	4ROW	6ROW
25	2500	80	67	86H	109H	121H	80	67	68	85	82	119
		90	72	115H	148F	163F	85	70	80	100	96	140
		100	75	132F	170F	193F	90	72	87	109	104	154
		110	81	183F	221F	250F	95	75	98	124	118	174
35	3500	80	67	130H	162H	183H	80	67	100	126	120	175
		90	72	174H	221F	245F	85	70	117	147	140	206
		100	75	203F	255F	284F	90	72	126	160	150	227
		110	81	274F	338F	375F	95	75	145	183	174	377
50	5000	80	67	174H	216H	248F	80	67	138	173	166	241
		90	72	231H	291H	328F	85	70	161	202	193	283
		100	75	272H	341F	381F	90	72	173	221	208	311
		110	81	370F	448D	501D	95	75	199	250	236	353
70	7000	80	67	244H	303F	341F	80	67	184	230	220	323
		90	72	328F	410F	460F	85	70	215	274	253	379
		100	75	384F	376F	581D	90	72	232	292	273	419
		110	81	513F	628D	705D	95	75	266	332	316	472
100	10000	80	67	348F	434F	493F	80	67	277	348	330	485
		90	72	468F	582D	661D	85	70	323	402	383	569
		100	75	545D	684D	767D	90	72	348	440	415	625
		110	81	740D	900D	1003D	95	75	399	505	476	708
130	13000	80	67	450H	563F	643F	80	67	359	450	430	630
		90	72	601F	760F	853D	85	70	420	427	504	740
		100	75	712F	887D	997D	90	72	452	575	540	812
		110	81	960D	1170D	1301D	95	75	519	565	620	920
160	16000	80	67	550F	697F	791D	80	67	424	533	509	742
		90	72	741F	936D	1054D	85	70	495	521	594	872
		100	75	875D	1093D	1223D	90	72	533	677	640	956
		110	81	1182D	1440D	1610D	95	75	611	774	733	1085
200	20000	80	67	690F	870D	993D	80	67	553	695	660	968
		90	72	932D	1175D	1320D	85	70	646	811	771	1140
		100	75	1091D	1368D	1531D	90	72	696	884	835	1250
		110	81	1480D	-	2014D	95	75	798	1010	958	1416
250	25000	80	67	870H	1093F	1238F	80	67	681	855	817	1192
		90	72	1172F	1462F	1649F	85	70	796	1000	954	1400
		100	75	1368F	1717F	1925D	90	72	857	1100	1028	1536
		110	81	1850D	2254F	2523D	95	75	983	1244	1180	1741
300	30000	80	67	1044F	1309F	1486F	80	67	796	1010	955	1394
		90	72	1400F	1753F	1980F	85	70	930	1168	1116	1639
		100	75	1640F	2051F	2303D	90	72	1000	1273	1200	1800
		110	81	2218D	-	2021D	95	75	1150	1454	1380	2040
350	35000	80	67	1201F	1526F	1934F	80	67	951	1196	1140	1665
		90	72	1635F	2053F	2310D	85	70	1111	1396	1333	1958
		100	75	1918F	2394F	2686D	90	72	1196	1520	1435	2149
		110	81	2585D	-	3525D	95	75	1373	1735	1648	2435
400	40000	80	67	1390F	1741F	1980F	80	67	1057	1329	1268	1852
		90	72	1871F	2341F	2639D	85	70	1234	1550	1481	2176
		100	75	2190D	2733F	3071D	90	72	1329	1690	1596	2387
		110	81	2960D	-	4035D	95	75	1525	1930	1830	2700



شرکت تولیدی صنعتی
داتیس کار

NOMINAL CAPACITY RATING

TABLE2:

MODEL	CFM	EDB°F	STEAM COIL RATINGS(K.B.H)				EDB°F	Heating Capacity K.B.H			
			8FPI ATV5 PSI*		14FPI ATV5 PSI*			Hot Water			
			1ROW	2ROW	1ROW	2ROW		1ROW	2ROW	3ROW	4ROW
250	2500	-20	202	368	243	445	-4	120H	211F	282F	348F
		10	177	324	213	389	14	105H	183F	237F	314F
		30	160	295	193	354	32	91H	158F	221F	250F
		60	136	251	164	301	60	69H	122F	176F	225F
350	3500	-20	303	552	364	660	-4	180H	319F	420F	516F
		10	190	485	228	581	14	158H	274F	358F	476F
		30	241	440	289	531	32	136H	234F	335F	380F
		60	204	376	245	451	60	108H	181F	267F	334F
500	5000	-20	405	735	486	882	-4	241H	421F	562F	691F
		10	355	647	424	776	14	212H	361F	473F	931F
		30	321	588	385	707	32	184H	315F	440F	500F
		60	271	500	326	601	60	136H	245F	351F	445F
700	7000	-20	567	1029	680	1335	-4	396H	593F	783F	965F
		10	497	905	596	1086	14	294H	510F	661F	882F
		30	449	824	539	988	32	260H	441F	614F	700F
		60	382	701	458	841	60	190H	332F	500F	620F
1000	10000	-20	809	1467	971	1762	-4	481H	845F	1123F	1384F
		10	708	1293	851	1551	14	421H	732F	949F	1270F
		30	640	1177	762	1412	32	370H	635F	881F	1000F
		60	544	1001	654	1200	60	274H	476F	709F	886F
1300	13000	-20	1051	1909	1261	2291	-4	624H	1101F	1467F	1800F
		10	920	1681	1100	2001	14	550H	956F	1230F	1640F
		30	833	1530	999	1834	32	483H	820F	1147F	1303F
		60	708	1302	848	1561	60	357H	623F	918F	1140F
1600	16000	-20	1292	2350	1551	2819	-4	775H	1356F	1801F	2213F
		10	1132	2068	1361	2481	14	676H	1178F	1516F	2022F
		30	1025	1883	1231	2257	32	595H	1011F	1413F	1606F
		60	871	1600	1045	1921	60	440H	768F	1132F	1405F
2000	20000	-20	1615	2937	1938	3523	-4	967H	1695F	2250F	2768F
		10	1415	2583	1700	3101	14	846H	1472F	1895F	2524F
		30	1281	1353	1535	2822	32	744H	1260F	1765F	2000F
		60	1089	2001	1300	2400	60	550H	965F	1416F	1765F
2500	25000	-20	2021	3671	2424	4409	-4	1210H	2120F	-	3460F
		10	1770	3232	2128	3877	14	1061H	1845F	-	3160F
		30	1605	2942	1920	3525	32	430H	1581F	-	2520F
		60	1360	2600	1632	3123	60	690H	1200F	-	2201F
3000	30000	-20	2423	4402	2900	5286	-4	1452H	2540F	-	4150F
		10	2124	3876	2550	4651	14	1272H	2208F	-	3790F
		30	1920	3528	2302	4236	32	1117H	1896F	-	3015F
		60	1630	3000	1958	3600	60	827H	1440F	-	2642F
3500	35000	-20	2828	5136	3394	6168	-4	1960H	2950F	-	4841F
		10	2478	4522	2978	5424	14	1480H	2571F	-	4420F
		30	2242	4118	2688	4939	32	1302H	2210F	-	3514F
		60	1905	3500	2287	4200	60	996H	1680F	-	3085F
4000	40000	-20	3234	5871	3879	7045	-4	1934H	3391F	-	5636F
		10	2832	5168	3400	6200	14	1694H	2944F	-	5506F
		30	2560	4705	3000	5645	32	1482H	2526F	-	4016F
		60	2178	4000	2611	4800	60	1244H	2151F	-	3590F



شرکت تولیدی صنعتی
داتیس کار

FAN RATINGS

TABLE3:

MODEL	Fan DIA.	Fv.FPM	CFM	Total Static Pressure (inch of water Gage)													
				1"		1.5"		2"		2.5"		3"		4"		5"	
				RPM	HP	RPM	HP	RPM	HP	RPM	HP	RPM	HP	RPM	HP	RPM	HP
25	14"	400	2000	683	0.75	-	-	-	-	-	-	-	-	-	-	-	-
		500	2500	695	0.75	841	1.5	-	-	-	-	-	-	-	-	-	-
		600	3000	720	1	847	1.5	969	2	-	-	-	-	-	-	-	-
		700	3500	762	1.5	869	2	977	3	1086	3	-	-	-	-	-	-
35	16"	400	3000	614	1	756	1.5	887	2	-	-	-	-	-	-	-	-
		500	3750	644	1.5	754	2	867	3	-	-	-	-	-	-	-	-
		600	4500	690	2	783	3	875	3	968	4	1061	4	-	-	-	-
		700	5250	745	3	829	3	941	3	985	4	1064	4	-	-	-	-
50	17"	400	4000	567	1.5	686	2	797	3	-	-	-	-	-	-	-	-
		500	5000	600	2	697	3	788	4	882	4	974	5.5	-	-	-	-
		600	6000	658	3	712	3	811	4	887	5.5	964	7.5	1120	7.5	-	-
		700	7000	686	4	787	5.5	853	5.5	918	7.5	982	7.5	1121	10	-	-
70	19"	400	5520	520	2	-	-	-	-	-	-	-	-	-	-	-	-
		500	6900	550	3	645	4	738	5.5	832	5.5	1003	10	1078	10	-	-
		600	8500	595	4	674	5.5	750	5.5	826	7.5	980	10	1067	15	1189	15
		700	9600	640	5.5	702	7.5	770	7.5	840	10	986	15	1060	15	1183	20
100	22"	400	8300	449	3	544	4	636	5.5	719	7.5	-	-	-	-	-	-
		500	10400	478	4	552	5.5	628	7.5	703	10	777	10	-	-	-	-
		600	12400	516	5.5	580	7.5	643	10	705	10	765	15	896	15	-	-
		700	14490	556	7.5	618	10	673	10	726	15	780	15	887	20	995	25
130	22"	400	10760	485	4	557	5.5	630	7.5	702	10	776	10	-	-	-	-
		500	13500	-	-	598	7.5	656	10	713	15	771	15	888	20	999	25
		600	16100	-	-	630	10	702	15	752	15	799	20	895	20	992	25
		700	18780	-	-	710	15	756	20	861	20	843	20	930	25	1008	30
160	26"	400	12780	-	-	473	7.5	540	7.5	600	10	650	15	-	-	-	-
		500	16000	411	5.5	508	10	560	15	600	15	640	15	750	20	-	-
		600	19000	457	7.5	554	15	600	15	637	20	670	20	760	25	835	30
		700	22690	509	15	604	20	650	20	680	25	710	25	780	30	850	40
200	29"	400	16500	364	4	419	7.5	475	10	534	10	-	-	-	-	-	-
		500	20000	400	7.5	445	15	490	15	538	15	580	20	670	25	-	-
		600	24600	445	15	490	15	529	20	565	20	600	25	672	30	751	40
		700	28500	-	-	533	25	569	25	601	30	630	30	697	40	759	50
250	29"	400	20000	403	10	450	15	494	15	538	15	582	20	656	25	-	-
		500	26000	460	15	500	20	538	20	573	25	605	25	679	30	750	40
		600	31000	-	-	556	25	588	30	621	40	651	40	710	40	768	50
		700	35000	-	-	-	-	647	40	675	50	703	50	758	50	808	60
300	26" *2	400	24500	428	5.5	496	5.5	567	7.5	643	10	-	-	-	-	-	-
		500	30000	468	7.5	529	10	581	10	637	15	694	15	801	20	-	-
		600	36500	518	10	569	15	619	15	663	15	709	20	801	25	900	30
		700	42000	671	15	569	20	660	20	700	20	741	25	819	30	900	30
350	26" *2	400	28700	442	5.5	501	7.5	558	10	618	5.5	681	15	-	-	-	-
		500	35670	498	10	568	15	596	15	641	15	687	20	780	20	880	30
		600	42300	557	15	630	15	644	20	684	25	721	25	800	30	880	40
		700	49700	-	-	676	25	700	25	737	30	537	30	839	40	902	40
400	29" *2	400	31680	385	7.5	425	10	503	10	656	15	-	-	-	-	-	-
		500	39700	428	10	471	15	532	15	568	15	618	20	667	25	-	-
		600	47500	476	15	518	20	560	20	598	25	635	25	675	30	796	40
		700	55600	-	-	564	25	600	25	700	30	670	30	702	40	803	50



شرکت تولیدی صنعتی
داتیس کار

HORIZONTAL AIR HANDLING UNIT

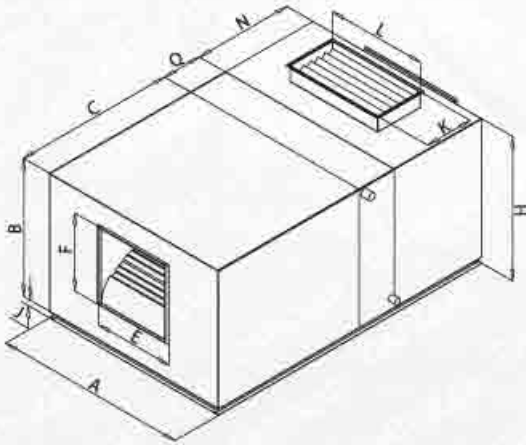

DAH 25 - 250

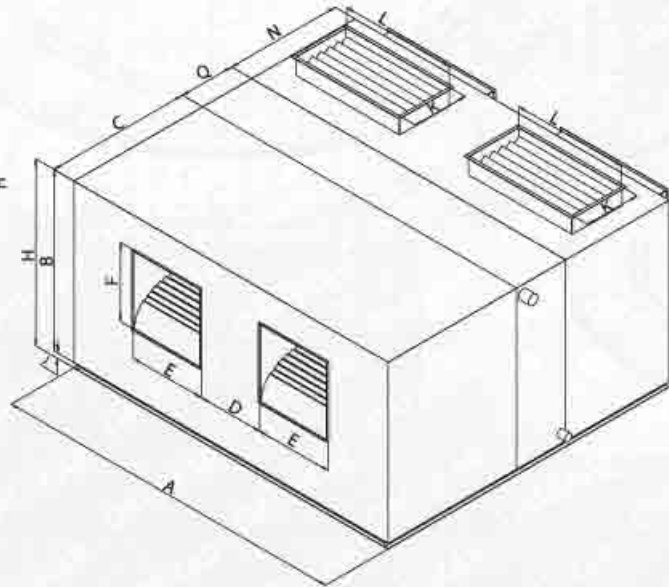

DAH 300 - 400

DATIS KAR AIR HANDLING UNIT

TABLE4- HORIZONTAL AIR HANDLING UNIT(WITH ANGLE FILTER) DIMENSIONS

MODEL	NOMINAL C.F.M	A	B	C	D	E	F	H	N	L	K	J	Q
DAH-25	2500	1200	850	1100	-	455	340	915	600	750	310	65	COOLING COIL WIDTH+ HEATING COIL WIDTH+ 250 WIDTH OF COILS: 1ROW = 140 2ROW = 140 3ROW = 170 4ROW = 200 6ROW = 240 8ROW = 350
DAH-35	3500	1300	850	1200	-	500	440	915	600	1000	310	65	
DAH-50	5000	1400	1100	1300	-	570	480	1180	700	1000	450	80	
DAH-70	7000	1600	1350	1400	-	600	650	1430	850	1250	595	80	
DAH-100	10000	2000	1500	1500	-	680	700	1580	850	1780	595	80	
DAH-130	13000	2000	1750	1500	-	680	700	1850	1000	1780	740	100	
DAH-160	16000	2250	1750	1650	-	750	810	1850	1000	2030	740	100	
DAH-200	20000	2500	2000	1800	-	840	910	2100	1200	2030	880	100	
DAH-250	25000	3100	2000	1800	-	840	910	2120	1200	2×1250	880	120	
DAH-300	30000	3800	2000	1650	800	750	810	2120	1200	2×1530	880	120	
DAH-350	35000	4150	2000	1650	1050	750	810	2140	1200	2×1780	880	140	
DAH-400	40000	4500	2000	1800	1200	840	910	2140	1200	2×2030	880	140	

All Dimensions in mm.



شرکت تولیدی صنعتی
داتیس کار

L - TYPE AIR HANDLING UNIT

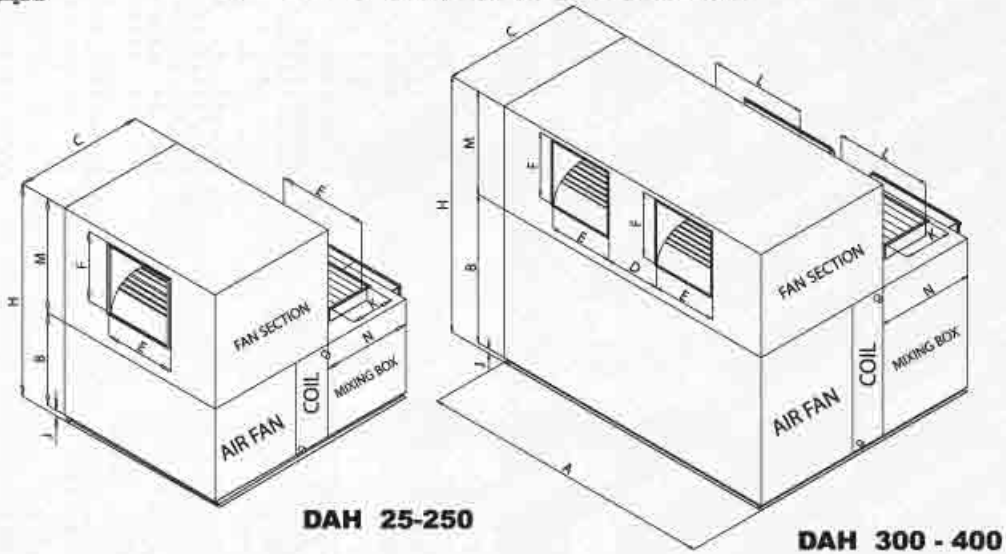

VERTICAL AIR HANDLING UNIT

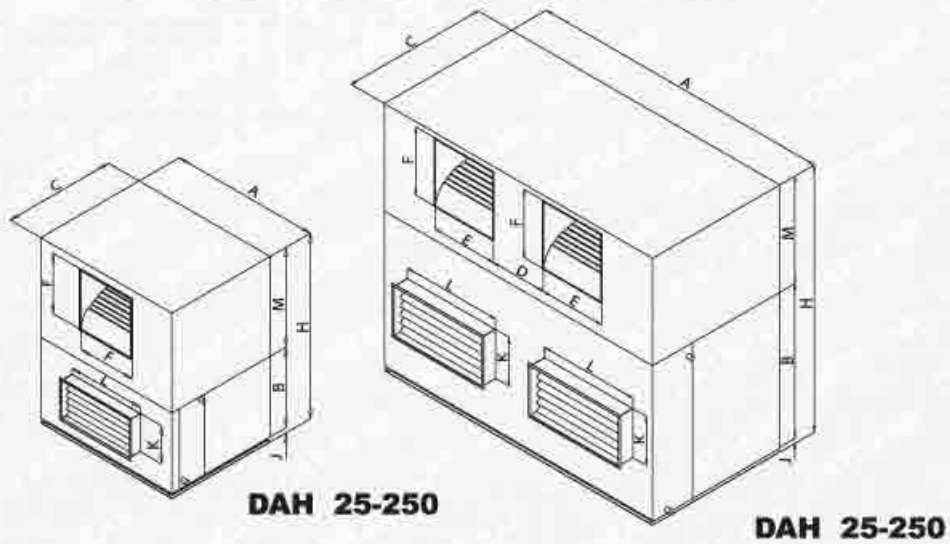

DATIS KAR AIR HANDLING UNIT

TABLES-VERTICAL AND L-TYPE AIR HANDLING UNIT DIMENSIONS

MODEL	NOMINAL C.F.M	A	B	C	D	E	F	H	M	N	L	K	J	Q
DAH-25	2500	1200	850	1100	-	455	340	1715	800	600	750	310	65	COOLING COIL WIDTH+ HEATING COIL WIDTH- 250 WIDTH OF COILS: 1ROW = 140 2ROW = 140 3ROW = 170 4ROW = 200 6ROW = 240 8ROW = 350
DAH-35	3500	1300	850	1200	-	500	440	1765	850	600	1000	310	65	
DAH-50	5000	1400	1100	1250	-	570	480	2130	950	700	1000	450	80	
DAH-70	7000	1600	1350	1350	-	600	650	2530	1100	850	1250	595	80	
DAH-100	10000	2000	1500	1500	-	680	700	2780	1200	850	1780	595	80	
DAH-130	13000	2000	1750	1550	-	680	700	3050	1200	1000	1780	740	100	
DAH-160	16000	2250	1750	1750	-	750	810	3250	1400	1000	2030	740	100	
DAH-200	20000	2500	2000	1800	-	840	910	3650	1550	1200	2030	880	100	
DAH-250	25000	3100	2000	1800	-	840	910	3670	1550	1200	2x1250	880	120	
DAH-300	30000	3800	2000	1850	800	750	810	3520	1400	1200	2x1530	880	120	
DAH-350	35000	4150	2000	1850	1050	750	810	3540	1400	1200	2x1780	880	140	
DAH-400	40000	4500	2000	1850	1200	840	910	3690	1550	1200	2x2030	880	140	

All Dimensions in mm.



شرکت تولیدی صنعتی
داتیس کار

TABLE 6:

COIL WATER SIDE PRESSURE DROP (FEED WATER)

MODEL	WATER FLOW RATE (GPM)												
	DAHU 25	DAHU 35	DAHU 50	DAHU 70	DAHU 100	DAHU 130	DAHU 160	DAHU 200	DAHU 250	DAHU 300	DAHU 350	DAHU 400	
WATER FLOW RATE (GPM)	1 2 4 6	1 2 4 6	1 2 4 6	1 2 4 6	1 2 4 6	1 2 4 6	1 2 4 6	1 2 4 6	1 2 4 6	1 2 4 6	1 2 4 6	1 2 4 6	1 2 4 6
10	0.4 0.3 0.6 0.9	0.2 0.3 0.4 0.6											
20	1.2 1 1.7 2.8	0.6 0.7 1 1.6 0.6 0.7 1 1.6											
30			1 1.2 1.7 2.7	0.8 1 1.4 2.2									
40			1.6 1.9 2.7 4.3	1.3 1.5 2.6 3.5	1.2 1.4 2 3.1								
50				2 2.4 3.4 5.4	1.6 2 2.7 4.3	1.1 1.3 1.8 3							
60					2.5 3 4 6.2	2.5 3.1 3.2 6.1	1.4 1.7 2.4 4						
70					3 3.8 4.1 7.5	1.8 2.2 3.1 4.9	2 2.4 3.4 5.4						
80					3.5 4 4.6 9	2.2 2.7 4 6	2.4 2.9 4.1 6.5	1.8 2.6 3.2 6					
100						3.1 3.7 5.3 8.4	3.4 4.1 6 9.2	3 3.6 5 8 0.8	1 1.4 2.2				
130						4.5 5.4 7.7 12	5 6 9 14	4.4 5.3 8 12 1.1 1.3	2 3 1.4 1.7 2.4	4			
150							6.1 7.3 10 17	5.8 6.4 9 14 1.3 1.6	2.2 3.5 1.7 2.1	3 4.6 1.3 1.7	2.2 3.5 1.4 1.7	2.4 3.8	
200								8 10 14 22	2.2 2.6 3.7 5.3	2.6 3.1 4.5 7 1.5 1.8	2.6 4.1 2.2 2.6	4 6	
250									3.6 5.1 8.1 3.6	4.3 6.1 10 2.8 3.4	4.5 7.6 3.1 4 5.3	8.4	
300										5 7 11 5 5.6	8 13 3.6 4.3	6.2 10 3.4 5 6.6	11
350											4.5 5.4 8 12	5 6 8.5 14	



شرکت تولیدی صنعتی
داتیس کار

TABLE7: CHILLED & HOT WATER COIL CONNECTION

MODEL	Chilled Water				Hot Water			
	2ROW	4ROW	6ROW	8ROW	1ROW	2ROW	3ROW	4ROW
DAH-25	1"	1 1/4"	1 1/4"	1 1/2"	3/4"	1"	1 1/4"	1 1/2"
DAH-35	1 1/2"	1 1/2"	1 1/2"	2"	1"	1 1/4"	1 1/2"	1 1/2"
DAH-50	1 1/2"	2"	2"	2"	1"	1 1/4"	1 1/2"	1 1/2"
DAH-70	1 1/2"	2"	2"	2"	1 1/4"	1 1/2"	2"	2"
DAH-100	1 1/2"	2"	2"	2"	1 1/4"	1 1/2"	2"	2"
DAH-130	2*1 1/2"	2*2"	2*2"	2*2"	2*1 1/4"	2*1 1/2"	2*2"	2*2"
DAH-160	2*1 1/2"	2*2"	2*2"	2*2"	2*1 1/4"	2*1 1/2"	2*2"	2*2"
DAH-200	2*1 1/2"	4*2"	4*2"	4*2"	2*1 1/4"	2*1 1/2"	2*2"	2*2"
DAH-250	4*1 1/2"	4*2"	4*2"	4*2"	4*1 1/4"	4*1 1/2"	4*2"	4*2"
DAH-300	4*1 1/2"	4*2"	4*2"	4*2"	4*1 1/4"	4*1 1/2"	4*2"	4*2"
DAH-350	4*1 1/2"	4*2"	4*2"	4*2"	4*1 1/4"	4*1 1/2"	4*2"	4*2"
DAH-400	4*1 1/2"	4*2"	4*2"	4*2"	4*1 1/4"	4*1 1/2"	4*2"	4*2"

TABLE8: STEAM COIL CONNECTION

Model	Supply		Condense	
25	1 1/2"	2"	1 1/2"	1 1/2"
35	1 1/2"	2"	1 1/2"	1 1/2"
50	2"	2"	1 1/2"	1 1/2"
70	2"	2"	1 1/2"	1 1/2"
100	2"	2"	1 1/2"	1 1/2"
130	2*2"	2*2"	2*1 1/2"	2*1 1/2"
160	2*2"	2*2"	2*1 1/2"	2*1 1/2"
200	2*2"	2*2"	2*1 1/2"	2*1 1/2"
250	4*2"	4*2"	4*1 1/2"	4*1 1/2"
300	4*2"	4*2"	4*1 1/2"	4*1 1/2"
350	4*2"	4*2"	4*1 1/2"	4*1 1/2"
400	4*2"	4*2"	4*1 1/2"	4*1 1/2"

**TABLE9: DX COIL CONNECTION*
SECTION/LIQUID**

Model	4ROW	6ROW
25	1/2"	5/8"
35	5/8"	5/8"
50	5/8"	5/8"
70	5/8"	7/8"
100	7/8"	7/8"
130	2*5/8"	2*5/8"
160	2*5/8"	2*5/8"
200	2*5/8"	2*5/8"
250	4*5/8"	4*5/8"
300	4*5/8"	4*5/8"
350	4*5/8"	4*5/8"
400	4*5/8"	4*5/8"



شرکت تولیدی صنعتی
داتیس کار

AIR WASHER

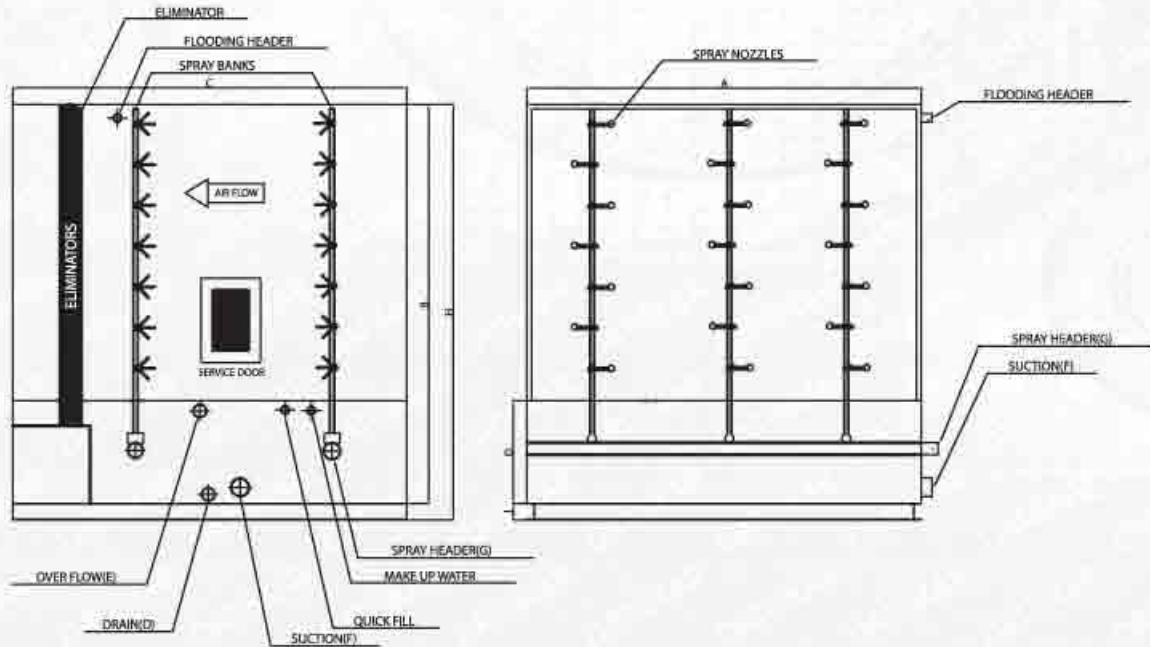

DATIS KAR AIR HANDLING UNIT

TABLE10-AIR WASHER DIMENSIONS AND SPECIFICATIONS

MODEL	NOMINAL C.F.M	FACE AREA ft ²	NOMINAL G.P.M			A	B	C	D	H	J
			CLASS 4	CLASS 6	CLASS 8						
DAW-25	2500	5	10	15	20	1200	1000	CLASS4:1250	300	1065	65
DAW -35	3500	7	14	21	28	1300	1000		300	1065	65
DAW -50	5000	10	20	30	40	1400	1250		400	1330	80
DAW -70	7000	14	28	42	56	1600	1450	400	1530	80	
DAW -100	10000	20	40	60	80	2000	1550	400	1630	80	
DAW -130	13000	26	52	78	104	2000	1800	CLASS6:1750	400	1900	100
DAW -160	16000	32	64	96	128	2250	1800		400	1900	100
DAW -200	20000	40	80	120	160	2500	2000		400	2100	100
DAW -250	25000	50	100	150	200	3100	2000	400	2120	120	
DAW -300	30000	60	120	180	240	3800	2000	CLASS8:2500	400	2120	120
DAW -350	35000	70	140	210	280	4150	2000		400	2140	140
DAW -400	40000	80	160	240	320	4500	2000		400	2140	140

All Dimensions in mm.



شرکت تولیدی صنعتی
داتیس کار

DATIS KAR AIR WASHER

TABLE11-AIR WASHER CONNECTIONS

MODEL	CLASS4				CLASS6				CLASS8			
	D	E	F	G	D	E	F	G	D	E	F	G
DAW-25	1½	2	2	2	2	2	2½	2	2	2	2½	2x2
DAW -35	1½	2	2	2	2	2	2½	2	2	2	2½	2x2
DAW -50	1½	2	2	2	2	2	2½	2	2	2	3	2x2
DAW -70	1½	2	2	2	2	2	3	2½	2	2	3	2x2
DAW -100	1½	2	2½	2½	2	2	3	3	2	2	3	2x2½
DAW -130	1½	2	2½	2½	2	2	3	3	2	2	3	2x2½
DAW -160	1½	2	2½	2½	2	2	3	3	2	2	3	2x2½
DAW -200	1½	2	3	2½	2½	2½	3	3	2½	2½	4	2x3
DAW -250	2	2½	3	2½	2½	2½	4	3	2½	2½	4	2x3
DAW -300	2½	2½	4	3	2½	3	4	3	3	3	5	2x3
DAW -350	2½	3	4	3	2½	3	4	3	3	3	5	2x3
DAW -400	2½	3	4	3	3	3	5	3	3	3	5	2x3

All Dimencsions in inch

TABLE12: AIR WASHER EVAPORATIVE COOLING PERFORMANCE

Model	EWB°F	CLASS-4				CLASS-4				CLASS-4			
		62	68	72	75	62	68	72	75	62	68	72	75
		LDB°F											
EDB°F													
DST 25 & DST 35	140	82	84	86	88	80	82	85	87	70	74	77	80
	95	78	80	82	84	76	79	81	83	69	72	76	79
	86	74	76	78	80	73	75	78	80	68	71	74	77
	82	72	74	77	78	71	74	76	87	67	70	74	76
DST 50 & DST 130	104	82	84	86	88	78	81	84	85	69	72	76	79
	95	78	80	83	84	75	78	80	82	68	71	75	77
	86	74	76	78	80	72	75	77	76	67	70	74	76
	82	72	74	77	78	70	73	76	77	66	69	73	76
DST 160 & DST 400	104	81	83	86	88	77	79	82	84	61	71	75	77
	95	78	80	82	84	74	76	79	81	67	70	74	77
	86	74	76	78	80	71	74	76	79	66	69	73	76
	82	72	74	77	78	70	73	75	77	65	69	73	76

TABLE12: SPECIAL FILTER FOR AIR HANDLING UNIT

Model		BAG & HEPPA FILTER NO .xsize
25	2500	1x(595x595) & 1x(295x595)
35	3500	2x(595x595)
50	5000	2x(595x595) & 1x(295x595)
70	7000	4x(595x595)
100	10000	4x(595x595) & 2x(295x595)
130	13000	6x(595x595) & 2x(295x595)
160	16000	8x(295x595)
200	20000	9x(595x595) & 3x(295x595)
250	25000	12x(595x595) & 3x(295x595)
300	30000	15x(595x595) & 3x(295x595)
350	35000	18x(595x595) & 3x(295x595)
400	40000	21x(595x595)



شرکت تولیدی صنعتی
داتیس کار

Air Washer / Air Handling Unit



تهران، خیابان میرداماد، میدان مادر، خیابان وزیری پور، کوچه خسروانی

پلاک ۴، طبقه ۴، واحد ۲۴ کد پستی: ۱۵۴۶۷۳۳۵۴۸

تلفن: ۸ - ۳۸۶۵ ۲۲۹۲ تلفکس: ۳۸۶۴ ۲۲۹۲

Web Site: www.datiskar.ir

E-mail: info@datiskar.ir

